

# 2-Shelf Steel Utility Cart

## SKU# 245-1056

Customer Service:  
2301 Traffic St. NE  
Minneapolis, MN 55413  
1-800-495-9278

**Thank You for your purchase of our product. The following contains assembly instructions as well as care and maintenance suggestions. Please take a moment to completely read and familiarize yourself with this information. If you have any questions regarding your purchase, please contact us at 1-800-495-9278**

1. **KEEP AWAY FROM CHILDREN:** Never allow children in a work area. Do not allow children to handle this product and any tools or equipment.
2. **STORAGE:** When not in use, always store in a dry location to resist rust. Always store in a secure location out of the reach of children.
3. **USE OF PRODUCT:** Never use inappropriate attachments or manipulate this product in an attempt to exceed this products capabilities. Inappropriate use or manipulation can cause serious injury and will void any and all warranties.
4. **MAINTAIN WITH CARE:** Always keep this product clean and properly assembled for safe and proper performance. Do not expose to corrosive materials



# IMPORTANT!

## PLEASE DON'T RETURN THIS PRODUCT TO THE STORE









- **HAVING PROBLEMS?**
- **NEED PARTS?**
- **INSTALLATION QUESTIONS?**
- **TROUBLESHOOTING?**

**CONTACT Customer Service 1-800-495-9278**

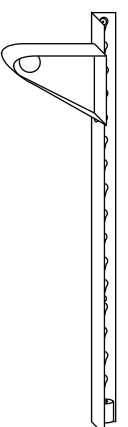
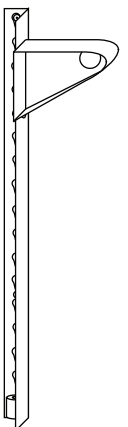
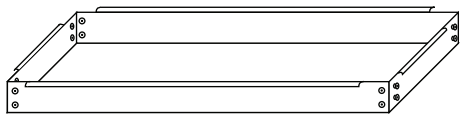
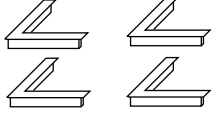
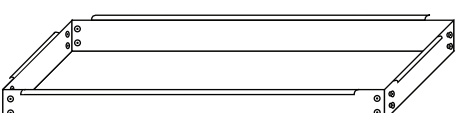
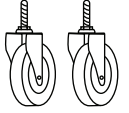
Monday-Friday: 8:00 am - 5:00 pm Central Time

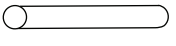
**WARRANTY:** This product is warranted for one year. If, during normal use, this Xtreme Garage™ product breaks or fails due to a defect in materials or workmanship, simply return it to a Menards® retail store for a free replacement of the same or a similar Xtreme Garage™ product or part. This warranty excludes expendable parts, and normal wear and tear on finishes. This Warranty is void if used in Commercial and/or rental purposes. And does not cover any loss to property or injuries to persons or property or related costs. This Warranty does give you specific legal rights, and you may have other rights which vary from State to State.

Tool Cart Parts List				Caster Wheel Wrench Included 	
					
<b>A</b>	<b>B</b>	<b>C</b>	<b>D</b>	<b>E</b> One Lower Tray	<b>I</b> Four End Caps
<b>Left Corner Brace</b>	<b>Right Corner Brace</b>	<b>Left Handle Brace</b>	<b>Right Handle Brace</b>		
				<b>F</b> One Upper Tray	<b>J</b> Two Caster Wheels
					
				<b>G</b> Eight Screws	<b>H</b> One Handle
					
					<b>K</b> Two Locking Caster Wheels

## Step 1 Assembly

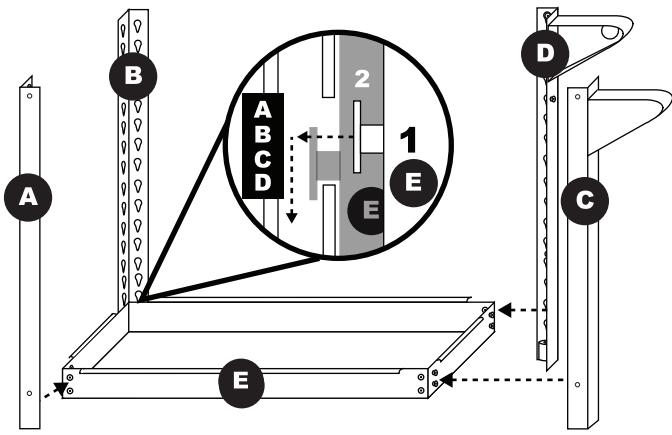

Connect the four braces (A)(B)(C)(D) to the lower tray (E) by sliding tray tabs into the bottom holes on all four corner braces. Use a rubber mallet to tap lightly on all four corners of lower tray (E) to secure.

## Step 2 Assembly

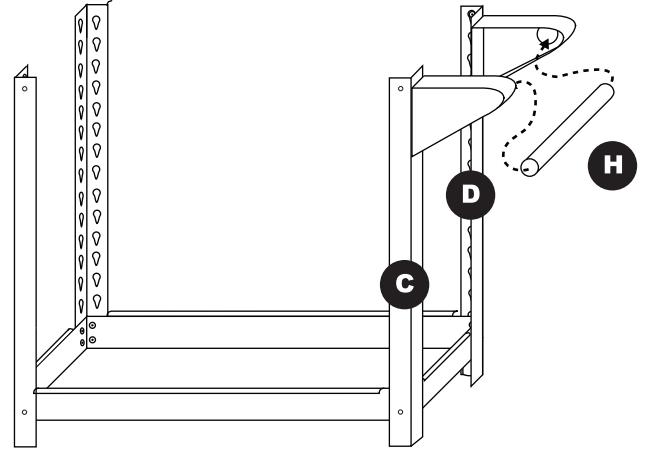

1. Slide handle (H) into the two handle braces (C)(D).

## Step 3 Assembly

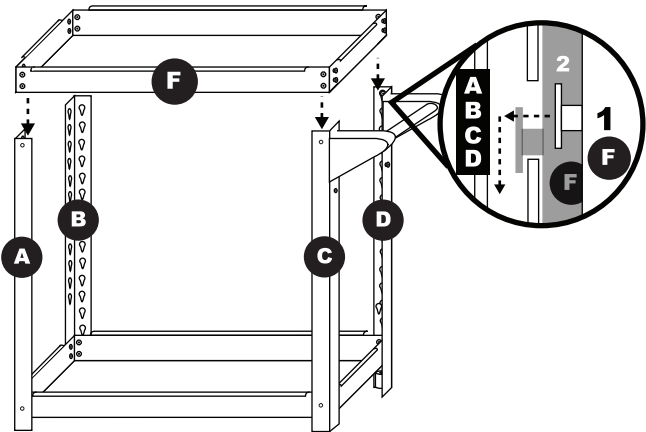

Connect the four braces (A)(B)(C)(D) to the upper tray (F) by sliding tray tabs into the top holes on all four corner braces. Use a rubber mallet to tap lightly on all four corners of upper tray (F) to secure.

## Step 4 Assembly

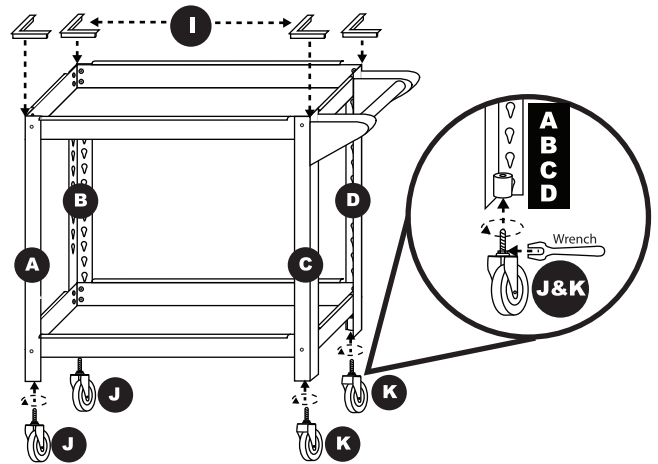

1. Using the supplied wrench screw in the four caster wheels (J&K) to the bottom of the four braces (A)(B)(C)(D). Tighten to secure.  
2. Install the four end caps (I) to the top of the four braces (A)(B)(C)(D).

## Step 5 Assembly

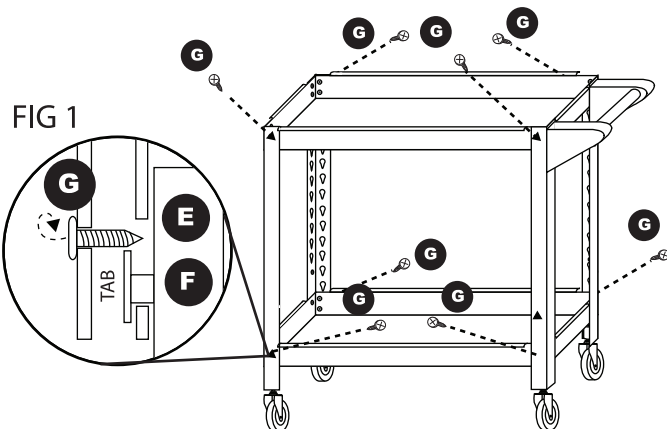

Using a screw driver install the 8 screws (G) into the holes located on all four corner braces. Screws (G) must thread in above the upper corner tabs (FIG 1) located on (E) and (F) to obtain proper fitment. Tighten to secure racking. You are finished, enjoy your tool cart!

## WARNING

**NEVER** overload cart, the maximum evenly spread weight capacity is **600lbs.** **NEVER** have a large unbalanced weight load of materials/supplies on the top of tray of cart. **ALWAYS** use on a stable, level surface at all times to prevent tipping. **NEVER** stand on service cart; or use as a device to stand or step on in any way or fashion. The above situations and any other misuse of this product can cause serious injury resulting in death or may cause serious damage to personal property.