

Owners Manual For Side Panels

SKU#136-5086, 136-5083, 136-5080

PLEASE READ THE FOLLOWING CAREFULLY

THE MANUFACTURER AND OR DISTRIBUTOR HAS PROVIDED THE PARTS DIAGRAM IN THIS MANUAL AS A REFERENCE TOOL ONLY: NEITHER THE MANUFACTURER NOR DISTRIBUTOR MAKES ANY REPRESENTATION OR WARRANTY OF ANY KIND TO THE BUYER THAT HE OR SHE IS QUALIFIED TO MAKE ANY REPAIRS TO THE PRODUCT OR THAT HE OR SHE IS QUALIFIED TO REPLACE ANY PARTS OF THE PRODUCT: IN FACT THE MANUFACTURER AND/OR DISTRIBUTOR EXPRESSLY STATE THAT ALL REPAIRS AND PARTS REPLACEMENTS SHOULD BE UNDERTAKEN BY CERTIFIED AND LICENSED TECHNICIANS AND NOT BY THE BUYER. THE BUYER ASSUMES ALL RISK AND LIABILITY ARISING OUT OF HIS OR HER REPAIRS TO THE ORIGINAL PRODUCT OR REPLACEMENT PARTS THERETO, OR ARISING OUT OF HIS OR HER INSTALLATION OF REPLACEMENT PARTS THERETO.

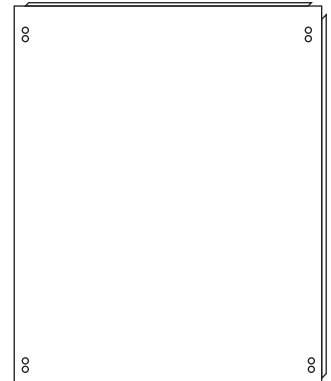

NOTICE

The Warnings, Cautions, and Instructions discussed in this instruction manual cannot cover all possible conditions and situations, which may occur. It must be understood by the operator that common sense and caution are factors, which cannot be built into this product, but must be observed by the owner or operator.

INSTRUCTIONS BEFORE USING IS PRODUCT!

- 1. WORK AREA / SURROUNDINGS:** Unclean cluttered work areas can cause environments. Do not use this product in damp, wet, or poorly lit location keep work area clean and well lit.
- 2. KEEP AWAY FROM CHILDREN:** "Never allow children in a work area" Do not allow children to handle this product and any tools or equipment.
- 3. STORAGE:** When not in use, always store in a dry location to resist rust. Always store in a secure location out of the reach of children.
- 4. USE OF PRODUCT:** Never use inappropriate attachments or manipulate this side panel kit in an attempt to exceed this side panel kits capabilities. Inappropriate use or manipulation can cause serious injury and will void any and all warranties.
- 5. USE PROPER SAFETY CLOTHING:** Wearing of loose clothing or cosmetic items may cause injury. When operating this product, use of eye protection, gloves, protective clothing, and nonskid footwear is recommended at all times. Always wear appropriate work clothing when using this product.
- 6. DO NOT OVERREACH:** "Keep proper footing and balance at all times" Never extend reach over or across tools or equipment.
- 7. MAINTAIN WITH CARE:** Always keep side panel kit clean and properly assembled for safe and proper performance.

Special warnings when using this side panel kit.

- 1. Wear appropriate eye protection, work gloves, safety shoes, and protective clothing when handling using this door assembly.**
- 2. Use caution when handling oils, tools, and work materials. Each can present hazardous situations. Check with all manufacturer's warnings and instructions when using other tools or materials.**
- 3. Do not use solvents or flammable materials to clean this doork kit. A mild soap detergent with warm water is sufficient. Solvents may damage the wheels or the paint and can create fire hazards.**

Customer Service:
Decko Products
2301 Traffic St. NE
Minneapolis, MN 55413
1-800-495-9278

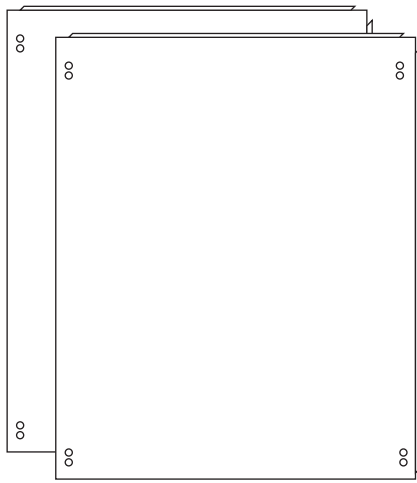

Tools Needed:

1. Phillips head screw driver.
2. Crescent wrench or 8mm Wrench.

Step 1 Assembly

The side panels can be assembled to any desired level on the racking system. Beams must be spaced exactly 12 slots apart in order for the panels to function properly.

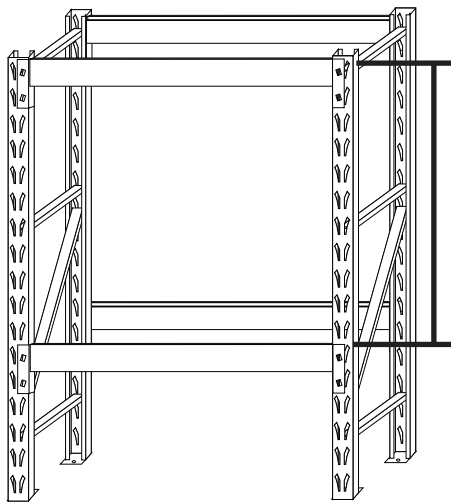

Beams must be spaced 12 slots.

Step 2 Assembly

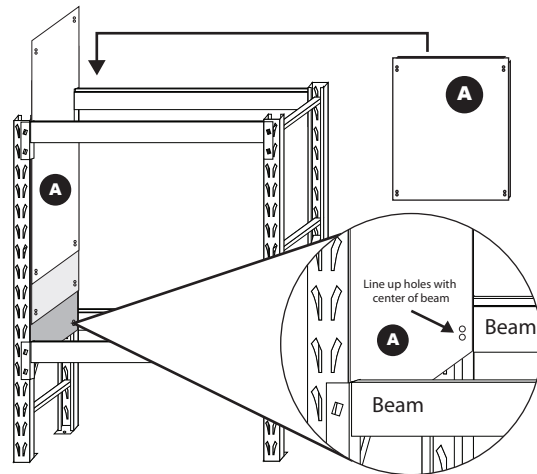

From the top, slide one side panel (A) between the beams and the end frames. Line up all holes with the center of the beams. If the holes are not in-line, the racking beams are incorrectly spaced and will need to be re-adjusted.

Step 3 Assembly

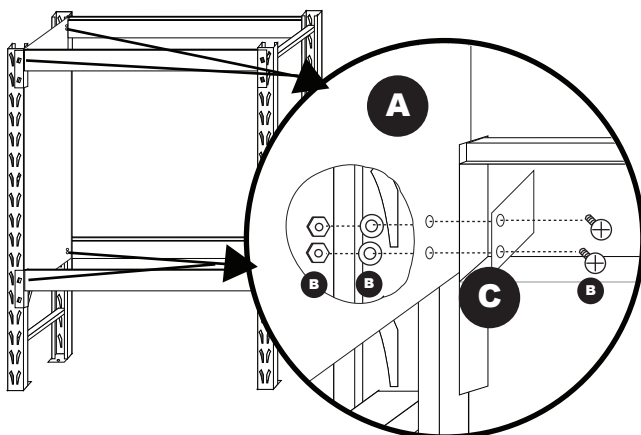

Attach one bracket (C) to each of the four corners of the side panels (A) using two screws (B) two washer (B) and two nuts (B). Once all four brackets are installed, tighten the brackets with a wrench and Phillips screw driver to secure.

Repeat steps 1,2,3 to install the second side panel (A)

Parts List

A Two Side Panels

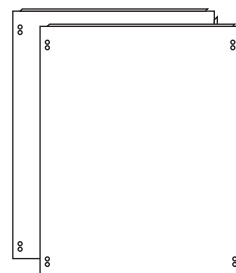

C Eight Brackets

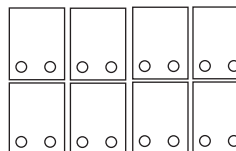

B Sixteen Screws Sixteen Nuts Sixteen Washers

