

Owners Manual For Door Kit

SKU#136-5095

Customer Service:
Decko Products
2301 Traffic St. NE
Minneapolis, MN 55413
1-800-495-9278

PLEASE READ THE FOLLOWING CAREFULLY

THE MANUFACTURER AND OR DISTRIBUTOR HAS PROVIDED THE PARTS DIAGRAM IN THIS MANUAL AS A REFERENCE TOOL ONLY: NEITHER THE MANUFACTURER NOR DISTRIBUTOR MAKES ANY REPRESENTATION OR WARRANTY OF ANY KIND TO THE BUYER THAT HE OR SHE IS QUALIFIED TO MAKE ANY REPAIRS TO THE PRODUCT OR THAT HE OR SHE IS QUALIFIED TO REPLACE ANY PARTS OF THE PRODUCT: IN FACT THE MANUFACTURER AND/OR DISTRIBUTOR EXPRESSLY STATE THAT ALL REPAIRS AND PARTS REPLACEMENTS SHOULD BE UNDERTAKEN BY CERTIFIED AND LICENSED TECHNICIANS AND NOT BY THE BUYER. THE BUYER ASSUMES ALL RISK AND LIABILITY ARISING OUT OF HIS OR HER REPAIRS TO THE ORIGINAL PRODUCT OR REPLACEMENT PARTS THERETO, OR ARISING OUT OF HIS OR HER INSTALLATION OF REPLACEMENT PARTS THERETO.

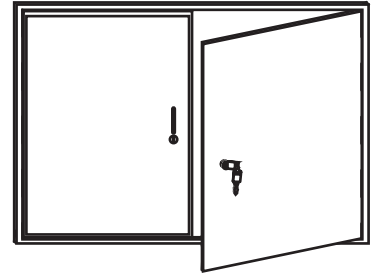

NOTICE

The Warnings, Cautions, and Instructions discussed in this instruction manual cannot cover all possible conditions and situations, which may occur. It must be understood by the operator that common sense and caution are factors, which cannot be built into this product, but must be observed by the owner or operator.

INSTRUCTIONS BEFORE USING IS PRODUCT!

- 1. WORK AREA / SURROUNDINGS:** Unclean cluttered work areas can cause environments. Do not use this product in damp, wet, or poorly lit location keep work area clean and well lit.
- 2. KEEP AWAY FROM CHILDREN:** Never allow children in a work area" Do not allow children to handle this product and any tools or equipment.
- 3. STORAGE:** When not in use, always store in a dry location to resist rust. Always store in a secure location out of the reach of children.
- 4. USE OF PRODUCT:** Never use inappropriate attachments or manipulate this door kit in an attempt to exceed this door kits capabilities. Inappropriate use or manipulation can cause serious injury and will void any and all warranties.
- 5. USE PROPER SAFETY CLOTHING:** Wearing of loose clothing or cosmetic items may cause injury. When operating this product, use of eye protection, gloves, protective clothing, and nonskid footwear is recommended at all times. Always wear appropriate work clothing when using this product.
- 6. DO NOT OVERREACH:** Keep proper footing and balance at all times" Never extend reach over or across tools or equipment.
- 7. MAINTAIN WITH CARE:** Always keep door kit clean and properly assembled for safe and proper performance.

Special warnings when using this door kit

- 1. Wear appropriate eye protection, work gloves, safety shoes, and protective clothing when handling using this door assembly.**
- 2. Use caution when handling oils, tools, and work materials. Each can present hazardous situations. Check with all manufacturer's warnings and instructions when using other tools or materials.**
- 3. Do not use solvents or flammable materials to clean this doork kit. A mild soap detergent with warm water is sufficient. Solvents may damage the wheels or the paint and can create fire hazards.**

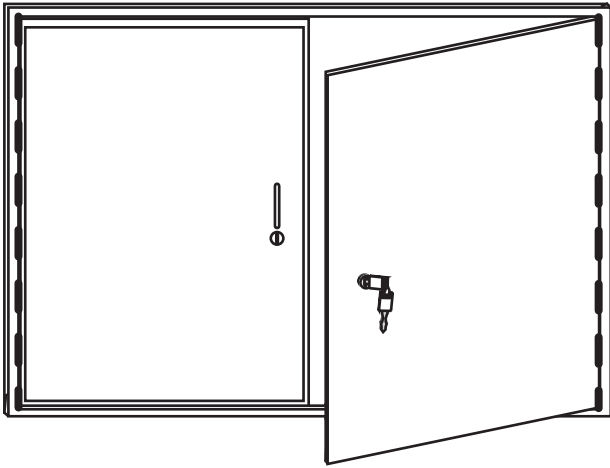

Tools Needed:

1. Flat head screw driver.
1. Two crescent wrenches.

Step 1 Assembly

The doors may be assembled to any desired level on the storage rack. Plan on having a 3 foot distance between shelves to create an enclosure.

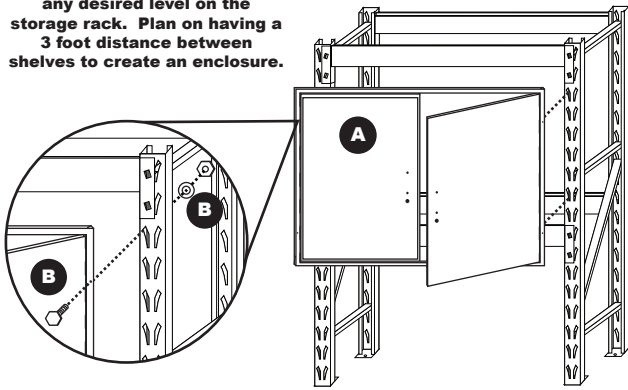

Attach the one door assembly (A) to the storage rack post with the four bolts (B) four washers (B) and four nuts (B). Start by aligning the top holes in the door assembly (A) with the 3rd key hole on the storage rack. Insert the bolt (B) and fasten with nut (B). Repeat the process for the bottom assembly holes. Make sure to tighten all four nuts securely.

Step 2 Assembly

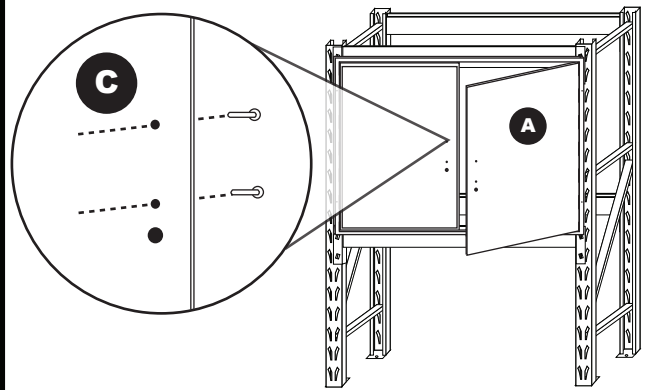

Assemble door handles (B) by first aligning the handle on the face of the door assembly (A). Insert handle screws (B) through the back of the door assembly (A) into the door handle (B) and then tighten the screws. Repeat all steps for second door handle.

Step 3 Assembly

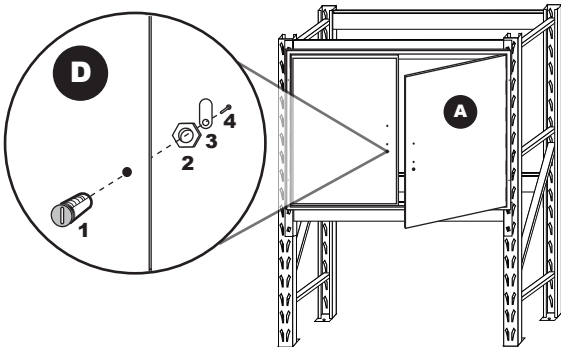

Remove the locking bar screw (4) from the main lock (1). Next remove the locking bar (3). Unscrew the large nut (2) from the main lock (1). Insert main lock (1) through the larger hole in the front of the door assembly (A). Thread large nut (2) onto main lock (1) and tighten securely. Re-install locking bar (3) onto main lock (1). Re-install locking bar screw (4) into the end of main lock (1). Repeat all steps to install second locking set.

Parts List

A One Door Assembly

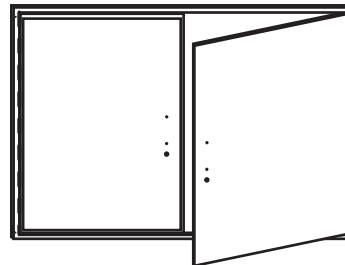

B Four Bolts Four Nuts

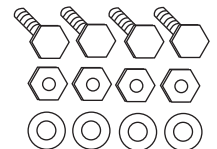

D Two Door Locks with Keys

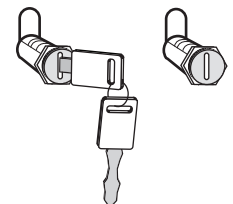

C Two Door Handles

